



STRIKE™

1/10-SCALE ELECTRIC SHORT COURSE TRUCK



LOSB0105 1/10 STRIKE Short Course Truck RTR

LOSB0105BD 1/10 STRIKE Short Course Truck Bind-N-Drive

CONNECT - REGISTER - WIN

Register your product online so we can notify you about the latest option parts, product updates, tech tips, service bulletins and more. Visit WWW.LOSI.COM and follow the Product Registration link to stay connected.

For registering your Losi Product you will be automatically entered for a chance to win the Losi-Pick-Your Prize Sweepstakes. The winner will be allowed to select a total prize package of \$1,000 (retail value) based on his/her preference.



Not Responsible for errors. All prices subject to change without notice.
Losi, a Division of Horizon Hobby, Inc.



Table of Contents

Introduction.....	2
Safety Precautions.....	3
Battery/Charging.....	3
Supplied and Required Equipment.....	4
Technical Overview.....	5-7
ESC Overview/Requirements.....	8
Transmitter Battery Installation.....	9
Vehicle Battery Installation.....	10
Quick Start.....	11
Losi DSM Radio System.....	12-13
Driving the 1/10 Strike SCT.....	14
Tuning, Adjusting and Maintaining.....	15-18
Troubleshooting the 1/10 Strike SCT.....	19
Warranty Information.....	20-21
Declarations of Conformity.....	22
RC Terminology.....	23
Parts Listing.....	24-25
Optional Parts Listing.....	25-26
Exploded Views.....	27-30
Notes and STRIKE Action Photos.....	31-33
Stock Setup Sheet.....	34
Blank Setup Sheet.....	35

Introduction

Thank you for purchasing the Losi® 1/10 Strike Short Course Truck. We are confident you will be satisfied with the performance of this durable and resilient vehicle.

Understanding that you are anxiously wanting to get your 1/10 Strike SCT ready for the open road, it will be to your long term benefit to make the effort and read through the entire manual. In the following pages you will find all the information you will need to set up as well as operate your new 1/10 Strike SCT to its full potential.

If you are an experienced RC hobbyist, or new to RC vehicles, it will benefit you to read all enclosed information.

From everyone at Losi we would like to thank you again for choosing the 1/10 Strike SCT. Our goal is helping people have fun and enjoy using our products.

Register your Losi Product Online

Register your 1/10 Strike SCT now and be the first to find out about the latest option parts, product updates and more. Log on to www.LOSI.com and follow the product registration link to stay connected.

Losi/Horizon Support

If you have any questions concerning setup or operation of your 1/10 Strike SCT please call Horizon Customer Support at 1-877-504-0233.

Hours:

Monday thru Friday from 8:00 am CST to 5:00 pm CST

In the United Kingdom please call Horizon Hobby UK Customer Support at +44 (0) 1279 641 097.

Getting Ready

Thoroughly read all the enclosed material, precautions and follow instructions to avoid damaging your new RC vehicle. If you choose to not follow these steps or instructions, it will be considered negligence.

If after review of this manual and prior to running your 1/10 Strike SCT, you determine this RC vehicle is not what you want—DO NOT proceed and DO NOT run the 1/10 Strike SCT. If the 1/10 Strike SCT has been run, your local hobby shop will not be able to process a return or accept it for exchange.

Caution:

THIS PRODUCT IS SUITABLE FOR CHILDREN 14 YEARS OR OVER. THIS PRODUCT IS NOT A TOY. This product is not intended for use by children without direct adult supervision. When driving the 1/10 Strike SCT it is important that you take measures to avoid someone being hit by the vehicle. You may cause serious injury to another person, or to personal property should you make contact while running the 1/10 Strike SCT.



Safety Precautions

We hope you operate this RC model in a safe, reasonable and cautious fashion in order to enjoy your vehicle. Should you operate this vehicle without a cautious and reasonable approach it may result in serious injury and/or property damage. Only you can control and make certain that safety precautions and instructions are followed.

General:

- The 1/10 Strike SCT is not a toy. This product is not intended for use by children without direct adult supervision.
- This RC vehicle is not intended for use on public highways or roads.
- Avoid an area that has many pedestrians or crowds of people.
- Keep in mind that this vehicle is radio controlled and can experience moments of radio loss or interference, so provide for a margin of error at all times.
- Please be aware that the motor and batteries of this RC vehicle will get HOT during each use. Be careful not to burn yourself.

Electronic Speed Control (ESC):

- Read all safety precautions prior to each use.
- Never leave the vehicle/ESC unsupervised while it is switched on, in use or connected to a power source. If there is a short-circuit or product defect, it could result in fire.
- If there are exposed wires, do not use the ESC until you have installed shrink-wrap or replaced the wire.
- Disconnect the battery from the ESC after use.
- The ESC is water-resistant, but should not be submerged or exposed to long periods of moisture.
- **Do not attempt to use more than a 2S LiPo battery or more than a 7-cell NiMH battery; doing so will damage the ESC and could result in fire.**
- Always turn on the transmitter first then the ESC to prevent an out-of-control vehicle.
- When setting your Electronic Speed Controller:
 - Please disconnect motor or remove the pinion gear during ESC setup or calibration functions.
 - Keep loose clothing, hair, gloves and fingers away from moving parts at all times.
 - Rubber tires can cause severe injury if there is a failure while running the vehicle while on a stand or when being held. Ensure rubber tires are securely mounted to the rims and if not, re-glue them and check them often for security.

Batteries and Charging:

The 1/10 Strike SCT uses rechargeable batteries such as NiMH or LiPo. These batteries require special handling to preserve performance and last a long time. Read all instructions and precautions that are provided with the batteries intended to be used in the 1/10 Strike SCT.

- Read all instructions provided by the manufacturer of the batteries.
- Responsible adult supervision is necessary while charging batteries.
- Always check to ensure the polarity of battery connection is correct.
- Never leave batteries unattended while charging.
- Never charge a battery while it is installed in the 1/10 Strike SCT.
- Do not charge any battery that appears to have any damage.
- If there are exposed wires do not charge or use the battery until you have installed shrink-wrap or replaced the complete wire.

When charging NiMH batteries, select a charger to meet your requirements. Chargers can be of two primary types for their source of power; a 100-240V wall charger, or one which requires a 12V power supply. Follow the charger manufacturer's instructions and precautions during each use.

Supplied and Required Equipment

Supplied Tools:



- 2-Way wrench
- Flat Turnbuckle Wrench
- Three (3) Hex Wrenches (L shaped) 3/32, 5/64, and 1/16
- Bind Plug

Recommended Accessories:

- Hobby grade knife
- CA glue (LOSA7880 or LOSA7881)
- Needle-nose pliers
- Side-cutting pliers
- Double-sided tape (LOSA4004)
- Safety Goggles
- Soldering iron

Required Equipment:

- ① A Six (6) cell NiMH or 2S LiPo battery pack.



Vehicle Battery
(6-Cell 7.2V "Stick Pack")
LOSB9903

- ② Four (4) AA batteries
- ③ NiMH battery charger with automatic "peak detection" or LiPo-compatible charger recommended.



MultiPro™ Intelligent Balance Charger (LOSB9606)

Using Your Charger:

If you do not yet have a charger, a peak detecting charger will provide the performance required and take care of your expensive batteries.

A popular choice for a charger would be a peak detection charger that can be plugged into a household AC wall socket. The peak detection portion of the charger monitors the battery charging and will automatically shut off upon full charge.

Other peak detection chargers require a 12V power source to charge your batteries. You would need to use or purchase a hobby grade 12V power supply before charging.

If you are going to be using a charger other than a peak detection charger it is important to have your battery fully discharged prior to recharging. Many of these have a timer that allows you to set the amount of charge time. If the battery was not fully discharged from prior use, you can potentially overcharge your battery pack.

If you are using a LiPo battery be sure to consult the manufacturer's suggestions for an appropriate LiPo-compatible charger. Chargers designed for NiMH cells only should never be used to charge your LiPo batteries and could result in serious injury.

Do not charge any battery unattended, and monitor for heat build up. If the battery pack is more than warm to the touch immediately discontinue charging.

Read all safety precautions supplied by the charger manufacturer, and also any from the battery manufacturer.

The Losi 1/10 Strike SCT Overview

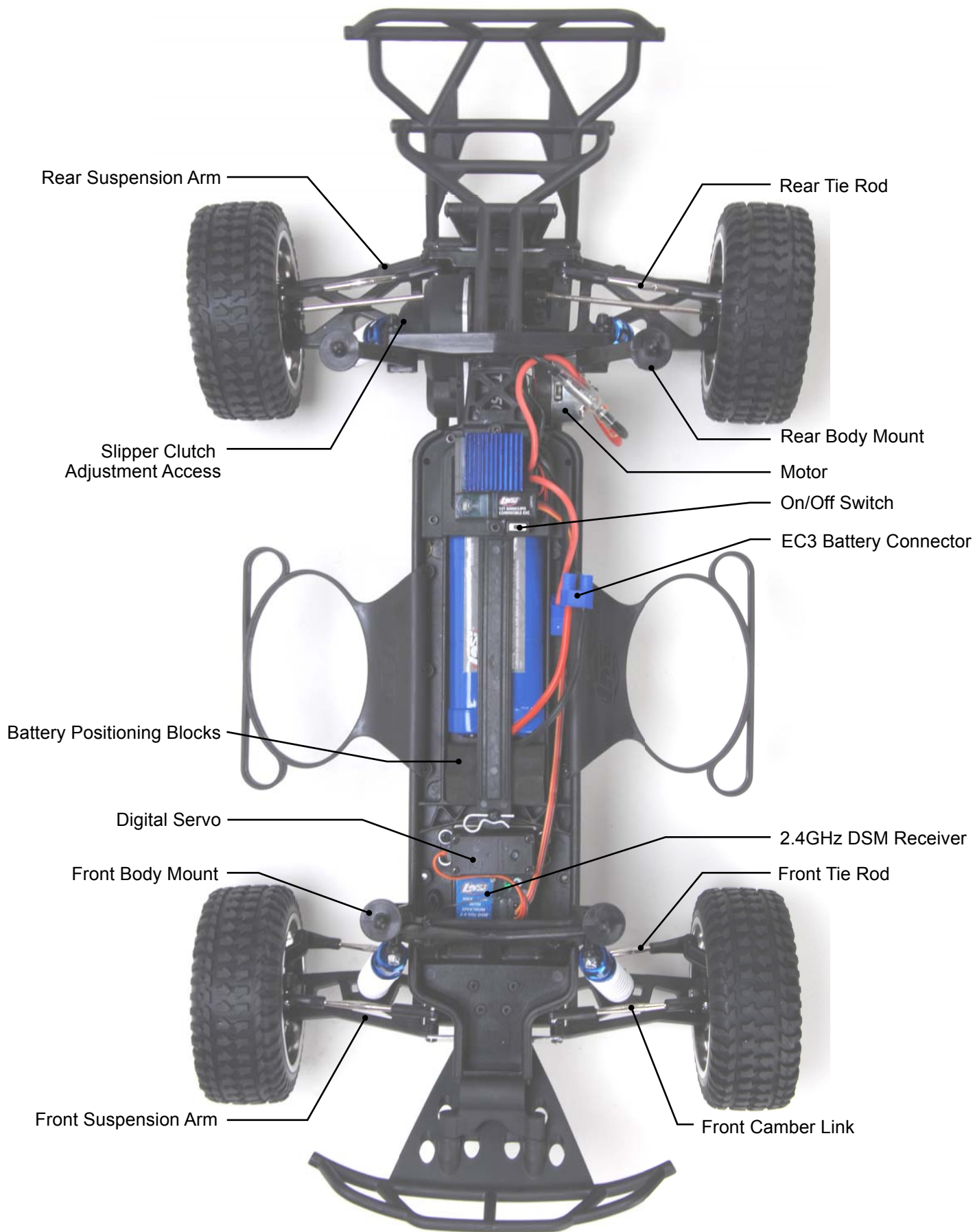

The Losi LSR-3000 Radio System Overview

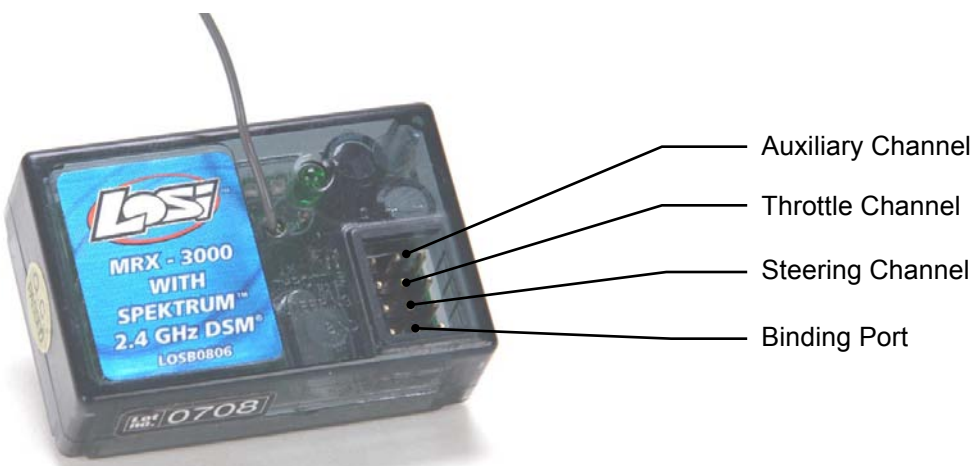

1/10 Strike SCT Electronics System Overview

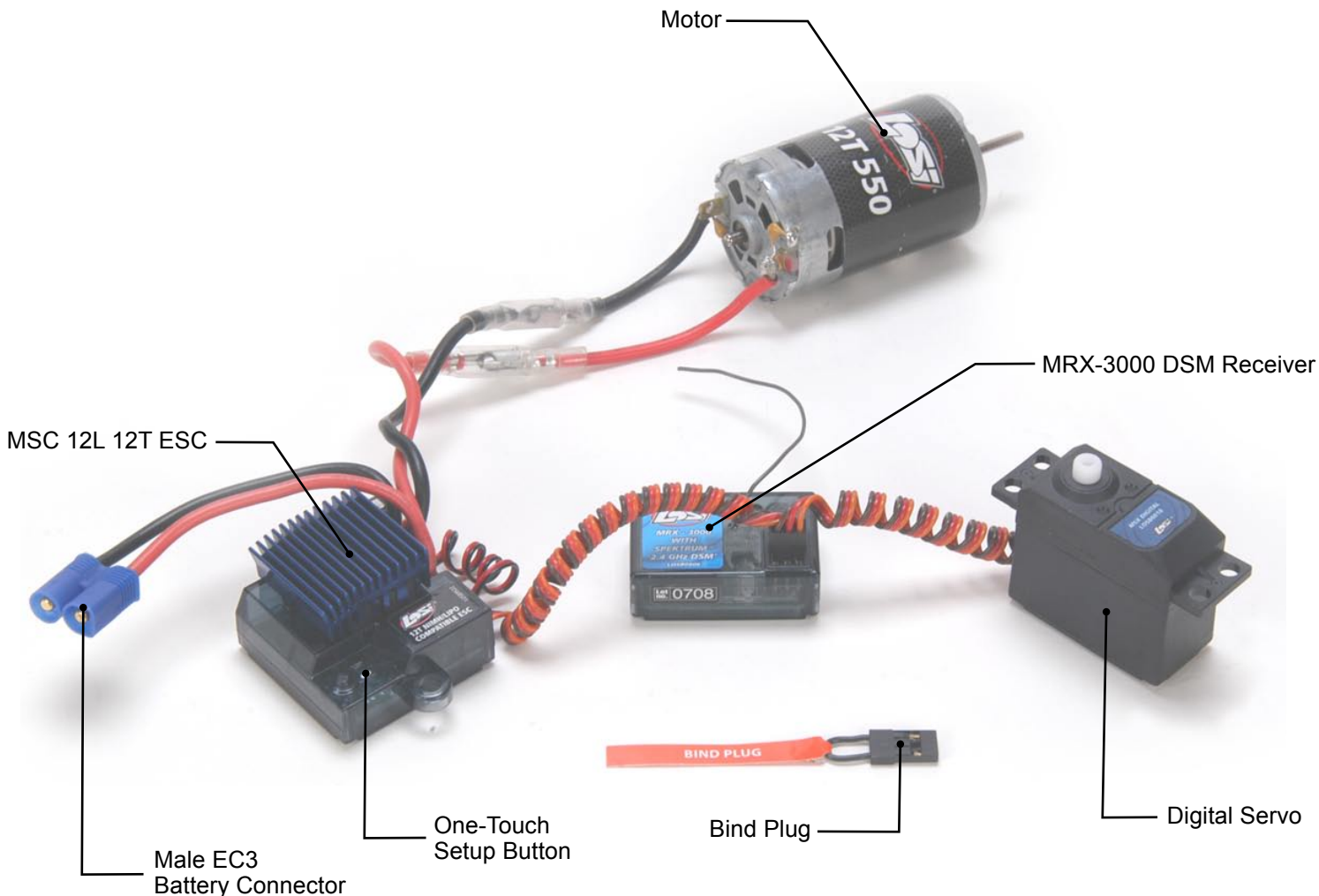



MSC-12L Fwd/Rev ESC

Features

- LiPo, NiMH/NiCd compatible
- 4 user selectable modes—Forward/reverse, Forward only race, Practice mode with slow acceleration, and Crawler.
- High-power FET control with proportional forward and reverse.
- High frequency design delivers smooth speed transition.
- Thermal Overload Protection prevents damage due to over current conditions.
- Pre-wired with EC3 battery plug and bullet-style motor connectors.
- Designed to operate with stock motors (12 turns or higher).
- Push-button programming with one touch setup.
- Water-Resistant

Specifications

Operation.....	Proportional forward, proportional reverse with braking delay
Input Voltage	4-cell (4.8 volts) to 6-cell (7.2 volts) DC NiMH/NiCd or 2S LiPo (7.4 volts)
Peak Current	1000A Forward and 350A Backwards
Continuous Current	250A Forward and 125A Backwards
Full-On Resistance	0.0014 Ohms Forward 0.0028 Ohms Backwards
Frequency	1kHz
BEC output	5V DC, 1 amp max. at 7.2V
Overload Protection.....	Thermal
Dimensions	1.575 in x 1.575 in x 1.063 in (40mm x 40mm x 27mm)
Weight	1.87 oz (53 g)

Connecting the Battery

The MSC-12L comes pre-wired with an EC3 connector. Use battery packs from 4-cell (4.8-volt) to 7-cell (8.4-volt) sub-C size battery packs or with 2S LiPo packs (7.4-volt).

1. Be sure the on/off switch is in the "off" position.
2. Connect a fully charged battery pack to the speed control's battery connector.

Adjusting the Transmitter

1. Set the "throttle reversing" switch to the NORMAL position.
2. Set the "throttle trim" to the CENTER position.

Speed Control Programming

NOTE: While in the programming mode, no power is applied to the motor.

Battery Selection: When the ESC is powered on, the LED will be flashing for 2 seconds to indicate the Selected Battery Type. During this time the user can press the key to toggle between LiPo and NiMH/NiCd modes. After the key has been pressed (battery type selected), the LED will flash for 2 more seconds.

- A. Turn on ESC and push button once within 2 seconds, push again to toggle between modes.
- B. Red light indicates LiPo mode (with 6-volt cutoff)
- C. Green light indicates NiMH/NiCd mode

One Touch Endpoint Setup

NOTE: Please be sure to set all throttle trim settings to neutral before performing an endpoint setup.

- A. Hold button and turn on ESC until the Red/Green light comes on. Once on, release button.
- B. Pull trigger to full throttle position until the green light goes from flashing to solid. Once solid, your forward endpoint is now set.
- C. To set reverse endpoint, push the trigger into the full reverse position until the flashing red light turns solid. At this point your reverse/brake endpoint is now set.
- D. Return trigger to neutral setting. The green light will now be solid and you are ready to go!

Selecting Speed Controller Modes

To change modes on your MSC-12L hold the setup key for over 5 seconds while in neutral. Once you find desired mode, simply release the key and you are ready for action.

- Forward/Reverse mode—Solid Green LED
- Forward Only mode—Fast Flashing Green LED
- Practice mode—Slow Flashing Green LED
- Crawler mode*—Solid Green and Red LED

**NOTE: Crawler mode is for use in rock crawling vehicles only. Do not use this mode with your 1/10 Strike SCT. Doing so may damage the vehicle.*

Troubleshooting Guide

Symptom	Solution
Steering servo operates but the motor does not run	Programming is not complete. Reprogram the ESC by following the programming instructions. Speed control connected to receiver incorrectly. Motor defective. Test motor independently, repair or replace as needed. Low batteries. Charge as needed. Overload Protection enabled. Check motor and connections.
Steering and motor do not function	Receiver wired incorrectly. Check polarity and orientation of controlplugs. Batteries discharged. Recharge or replace.
Full speed not attainable	Transmitter adjusted improperly. ESC programmed incorrectly. Reprogram.
Motor slows but will not stop	Throttle trim may be set improperly. ESC program does not match transmitter. Reprogram ESC.
Reduced radio range/Interference	Motor capacitors broken/missing. Repair or replace. Motor noise. Move receiver further away from ESC, motor and wiring. Transmitter batteries low. Replace batteries.

Installing Batteries:

Transmitter

Remove the battery cover from the bottom of the transmitter by sliding it away from the base of the handle. Install the four (4) AA-size batteries into the base, noting polarity when inserting each battery.



Reinstall the battery cover by sliding it back on the handle base.

Battery Pack(s):

To install the battery pack remove the battery hold-down strap by removing the clip from the front mounting boss, and then, while lifting the strap, pulling forward in one motion.

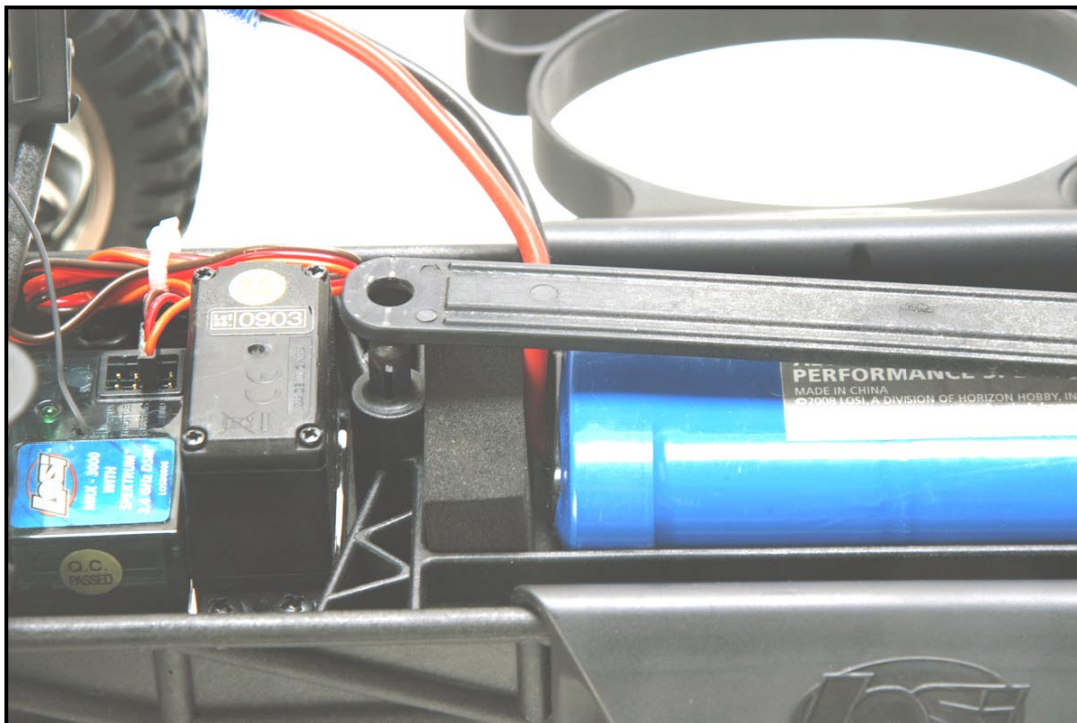

After you have inserted the fully-charged battery pack reinstall the battery hold-down strap.

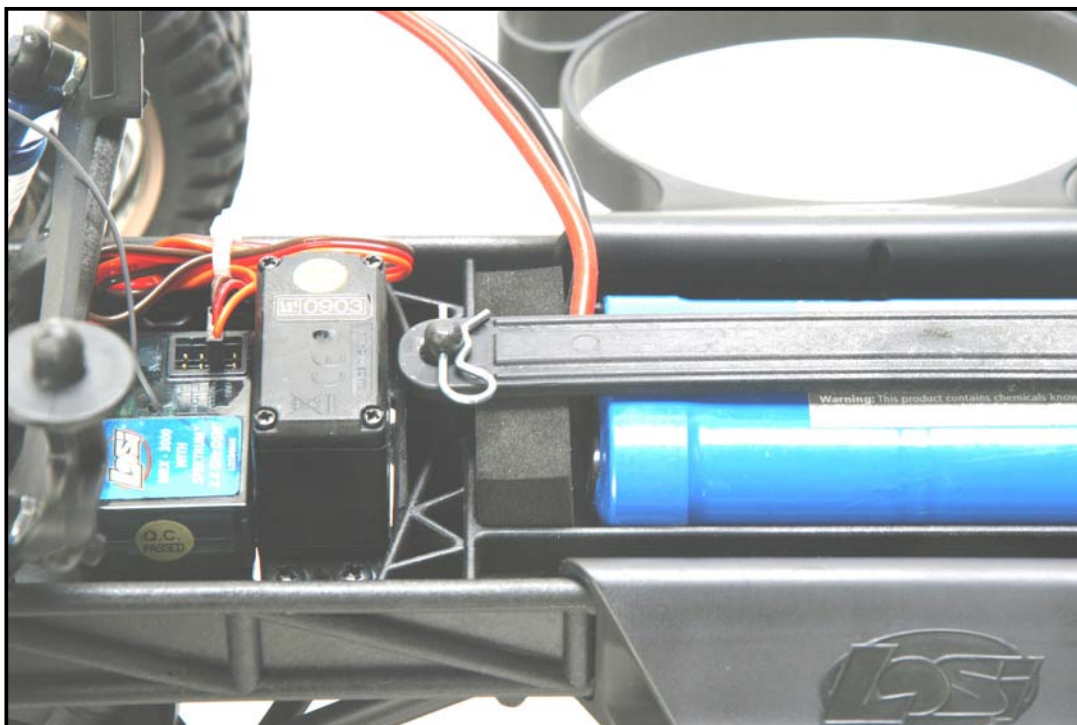

Notice that the battery hold-down has a flat side while the other side has strengthening ribs; the rib side should be facing down to the battery.

Insert on an angle into the rear support, and then down on the front pin and secure it with the previously removed clip.

Quick Start

Note: Please read the entire manual to gain a full understanding of the 1/10 Strike SCT vehicle, fine-tuning the setup and performing maintenance.

- 1. Read the safety precautions found on page 3. This is important for your safety and prevention of personal injury.
- 2. Charge the battery pack you have chosen (NOT INCLUDED). Refer to the manufacturer's supplied instructions for battery charging information.
- 3. Install the AA batteries into the Losi LSR-3000 transmitter (see page 9). Use alkaline or rechargeable batteries only.
- 4. Install the battery pack (see previous page). The battery pack should be fully charged before installation.
- 5. Turn on the transmitter and then the vehicle. It is a good practice to turn on the transmitter before the vehicle and turn it off after the vehicle has been turned off.
- 6. Check steering (see page 12). Verify that the servo is functioning properly.
- 7. Driving the 1/10 Strike SCT (see page 14).
- 8. Performing maintenance of the 1/10 Strike SCT. Refer to Tuning, Adjusting and Maintenance of the 1/10 Strike SCT on page 15.

The Losi LSR-3000 Radio System

The Losi LSR-3000 radio system with Spektrum™ 2.4GHz DSM® technology included with the 1/10 Strike SCT operates on 2.4GHz and provides 79 unique channels, which are automatically selected when the transmitter and vehicle are turned on. The communication between the transmitter and receiver begins in the few seconds after both are turned on.

They are bound from the factory to uniquely operate together.

The Losi LSR-3000 DSM radio system will not interfere with radio systems operating on legacy frequencies such as 27MHz or 75MHz, neither will you experience any overlapping interference from other 2.4GHz systems.



Transmitter

The Losi LSR-3000 transmitter has several adjustments available to increase your enjoyment of the 1/10 Strike SCT vehicle.

1. Power Switch – Turns the transmitter on and off.
2. Dual Rate – (ST.D/R) Adjusts how much the wheels can turn left/right in equal proportion.
3. Steering Trim – (ST.TRIM) Adjusts the “Hands Off” direction of the 1/10 Slider.
4. Throttle Trim – (TH.TRIM) Fine adjustment for the throttle and brake center.

Receiver

There is no adjustment required of the receiver. Please note the different slots for connection.

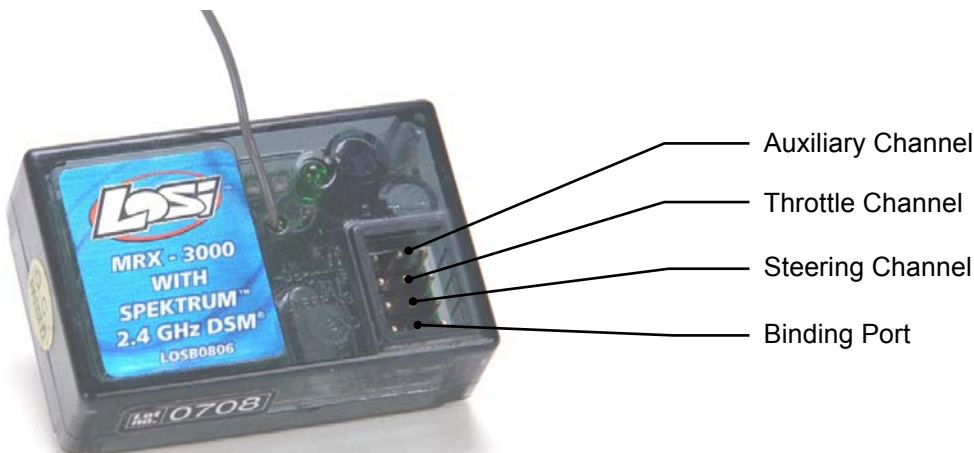

There are bind, channel one, channel two and auxiliary slots.

The bind slot is used to bind the transmitter to the receiver. The Losi LSR-3000 DSM® radio system uses a unique GUID ID to “bind” the transmitter to each receiver. This bind process has been performed during assembly and is described below should you replace the receiver or during a troubleshooting exercise when you are requested to rebind your transmitter and receiver.

Although the transmitter and receiver are set “bound” at the factory, below are the steps required to rebind your transmitter and receiver should the need arise.

Rebind Process

1. Ensure that the transmitter and vehicle are both turned off.
2. Using the supplied Bind plug (which looks like a standard receiver plug with a short wire loop installed), insert the Bind plug into the receiver slot labeled BIND. When you look down on the receiver slots, it is the slot farthest from the LED, and nearest to the corner of the receiver.

Note: You do not need to remove any other plugs to rebind.

3. With the bind plug installed, turn on the vehicle. Notice the LED is now blinking.
4. You are now ready to turn on the transmitter. You should notice on the back of the transmitter a similar blinking LED under a translucent cover.
5. Both the receiver and transmitter LEDs will stop blinking and be on solid, indicating that they have bound themselves together.
6. Turn off the vehicle and then the transmitter.
7. Remove the bind plug from the receiver.
8. Turn on the transmitter and then the vehicle to ensure operation. If the transmitter does not control the vehicle, please repeat steps 1--7 above. If after several attempts you are unsuccessful, please call Horizon product support.
9. The bind process is complete. Your vehicle's radio system is now ready for use.

Receiver Antenna

Using your fingers, gently straighten the antenna wire to be close to vertical from the chassis for the best radio reception.

Factory Settings of Radio/ESC

The Electronic Speed Control was calibrated together with the radio system at the factory. When you turn on and run the 1/10 Strike SCT for the first time, you may be required to slightly adjust the Throttle Trim. If the vehicle creeps in reverse or in forward, just make a fine adjustment to the Throttle Trim knob on the transmitter. Sometimes during the bumps and bounces of transportation the settings can be slightly altered.

Driving the Strike SCT

Please note the following precautions before running your 1/10 Strike SCT:

- The Electronics in this vehicle are not waterproof and you must avoid running the vehicle in or through standing water, wet grass, mud or snow.
- This vehicle is quick:
 - o Do not run the vehicle if it will be out of sight for any amount of time.
 - o Do not drive your vehicle near a crowd of people.
- Perform a check of the vehicle before going out to run it.
 - o Ensure the tires are not coming off the rims.
 - o Generally check the vehicle for items such as a loose wheel nut, or anything loose on the steering assembly. The vibrations of running off-road tend to loosen screws and nuts.
- Be careful driving when the battery is nearly discharged or the car is running slowly. You could lose enough power for the receiver to shut down and you may lose control.
- When driving the 1/10 Strike SCT be cautious and use common sense.
- If your vehicle gets caught or stuck, do not pull the throttle in either forward or reverse. This will overload the ESC and/or motor, resulting in damage to one or possibly both, and is not covered by your warranty.
- After running a battery pack, allow the electronics several minutes to cool, before running the next battery pack.

Run Time Consideration For The 1/10 Strike SCT Vehicle.

The single largest factor in run time is the capacity mAh of your battery pack. The larger the mAh rating, the more run time you will experience. On the same note, the longer you run, the hotter the battery plugs can get. Please check the standard plugs periodically.

For example: if you have a 4600mAh battery pack, you can expect close to twice the run time of a 2000mAh battery pack.

The condition of a battery pack is also an important factor in both run time and speed. As batteries see more use, they will degrade in performance and capacity.

How you drive your 1/10 Strike SCT will also affect your run times. If you are performing runs, going from a standstill to full speed repeatedly, you are asking a lot from your batteries and electronics. Hard acceleration draws a lot of current from any battery and will lead to shortened run time.

If the bearings are dirty they will cause significant drag leading to reduced run times and speed.

To improve run times consider the following:

- Keep your vehicle clean and maintained.
- Allow more airflow to the heat sink of the MSC-12L ESC.
- Change the gearing to a lower ratio, making the electronics run cooler. This can be accomplished by using a smaller pinion gear than those originally supplied. (The 1/10 Strike SCT comes with a 20-tooth pinion and a 90-tooth spur gear.)
- Change to battery packs of higher mAh ratings.
- Is the charger you're using the best at charging your batteries? Check with your local hobby dealer.

Tuning, Adjusting & Maintaining the 1/10 Strike SCT

Periodically examine your 1/10 Strike SCT for the following:

- Keep your vehicle clean using a brush to remove dirt and dust.
- Look for cracks in the suspension arms and other molded parts.
- Check that the tires are still glued to the wheels.
- Check that all the wheel bearings are clean and lubricated.
- Using your tools, attempt to tighten all the screws and nuts.
- Verify that the camber links and steering linkage are not bent.
- Check that the toe and camber settings are as desired and equal.
- Remove the gear cover.
 - o Check the spur gear for wear.
 - o Check the pinion gear.
 - o Check the slipper pads for wear.
- Take the shocks off the vehicle and check, especially if they appear to be leaking, as it is time to rebuild them.
- Look over all the wiring and connections for bare wire or any place which could lead to a short circuit.
- Verify that the ESC is securely mounted to the chassis.
- Verify the receiver is still securely mounted to the chassis.
- Turn on the radio. If the Green LED is off or dim, replace the 4 AA batteries in the transmitter.

After you become familiar with driving your 1/10 Strike SCT, you may need to reset or make adjustments for better driving performance.

Just as in a real car, alignment is an important factor in your vehicle's handling. When you are ready to make adjustments, it is a good idea to have a flat work space to place your vehicle on. This will enable you to easily and more quickly make both toe-in and camber adjustments. These adjustments should be set with the vehicle sitting at its normal ride height.

Tuning the Front End of the 1/10 Strike SCT

Shock Location:

The 1/10 Strike SCT has two mounting locations on the front shock tower. The position can be easily adjusted by simply moving the top of the shock to another hole. The standard location (inside hole on the tower) works best on most surfaces. Moving the top of the shock outward a hole will slow steering response and make the 1/10 Strike SCT smoother in bumps. Running the inside shock location on the arm will give the 1/10 Strike SCT more steering into the turn and less steering on corner exit. Running the shock location outside on the front arm will give you less overall steering into the turn and keep the front end flatter through the turn, making the 1/10 Strike SCT smoother and easier to drive. This can be used on high-traction surfaces.

Using the supplied flat metal turnbuckle wrench if you need to **SHORTEN** any link on the 1/10 Strike SCT, rotate the wrench towards the rear of the vehicle (clockwise). If you need to **LENGTHEN** any link then rotate the wrench towards the front of the vehicle (counterclockwise).

Static Camber:

This refers to the angle of the wheels/tires relative to the surface (viewed from either the front or back). Negative camber means that the top of the tire leans in toward the chassis. Positive camber means the top of the tire leans out, away from the chassis. Camber can be precisely measured with aftermarket camber gauges, sold at local hobby shops. It can be measured (roughly) using any square (to the ground) object by checking the gap between the square edge and the top of the tire. Testing has shown that 1 degree of negative camber is best for most track conditions. Increasing negative camber (in the range of 1-2 degrees) will generally increase steering. Decreasing negative camber (in the range of 0-1 degree) will generally decrease steering and the 1/10 Strike SCT will feel easier to drive as a result. This is, most often, a very critical adjustment in tuning your 1/10 Strike SCT that can be made quickly and easily.



Tuning the Front End of the 1/10 Strike SCT (CONT'D)

Inboard Camber Location:

NOTE: This is an adjustment that is difficult to make a generic statement for as it can have slightly different results on various conditions.

The following is a summary of how this adjustment will usually impact the handling of the 1/10 Strike SCT.

A longer front camber link will usually make the 1/10 Strike SCT feel stiffer. This will help keep the 1/10 Strike SCT flatter with less roll, but can make the 1/10 Strike SCT handle worse in bumpy conditions. It also will make the 1/10 Strike SCT easier to drive.

A shorter front camber link will result in more front end roll, which will provide more steering on tighter turns with the loss of some stability. You will also lose some high-speed steering but might gain some more steering response.

Too short of a front link may make the 1/10 Strike SCT feel “twitchy” or “wandery” meaning that it may be difficult to drive straight at high speed.

Tuning the Front End of the 1/10 Strike SCT (CONT'D)

Outboard Camber Location:

The 1/10 Strike SCT provides two outboard mounting options. The outer location helps the 1/10 Strike SCT stay tighter in turns with a more precise steering feel. Moving the link to the inner hole will make the steering react slightly slower and steer smoother. The advantage to the inner hole is that it can increase on-power steering and help the 1/10 Strike SCT get through bumps better.

Toe-In/Out:

This is the parallel relationship of the front tires to one another. Toe-in/out adjustments are made by changing the overall length of the steering tie rods. Toe-in (the front of the tires point inward, to a point in front of the front axle) will make the 1/10 Strike SCT react a little slower, but have more steering from the middle of the turn, out. The opposite is true with toe-out (the front of the tires point outward, coming to a point behind the front axle), the 1/10 Strike SCT will turn into the corner better but with a decrease in steering from the middle of the turn, out. Toe-in will help the 1/10 Strike SCT to track better on long, straight, high-speed runs, where toe-out has a tendency to make the 1/10 Strike SCT wander. We recommend to run between 0-degree of toe-in/out to 1 degree of toe-in.

Bump-In/Out:

Bump-out (front of the front tires toe-outward under suspension compression) will result in more off-power steering and less consistent handling if you have too much bump-out. This effect is obtained by adding washers under the steering spindle ball stud. Bump-in (front of the front tires toe-inward under suspension compression) will result in less off-power steering. Too much bump-in can make the steering feel very inconsistent. This effect is obtained by installing a ball stud washer on the bottom of the spindle. Testing has shown that running a little bit of bump-in (kit setup) in the 1/10 Strike SCT offers the best overall setup.

Caster:

This is the angle of the king pin from vertical when viewed from the side of the 1/10 Strike SCT. The 1/10 Strike SCT comes equipped with a 30-degree kick-up angle. Total caster is determined by adding the amount of kick-up (1/10 Strike SCT has 30 degrees) and the king pin angle of the front spindle carriers. Increasing total caster will provide more steering entering a turn but less on exit. Decreasing total caster will cause the steering to react faster and increase on-power steering.

Tuning the Rear End of the 1/10 Strike SCT

Shock Location:

Moving the shocks in on the arm will result in more forward traction and let the 1/10 Strike SCT drive more square off the turn.

Static Camber:

Having the same definition as for the front end and measured in the same fashion, rear camber can also be a critical tuning feature. Testing has shown that running a small amount of negative camber (.5-1 degree) is best. Increasing negative rear camber (in the range of 1.5-3 degrees) will increase stability and traction in corners, but decrease high-speed stability. Decreasing rear camber (in the range of 0-1.5 degrees) will decrease stability and traction in corners, but will increase high-speed stability.

Inboard Camber Location:

The 1/10 Strike SCT has multiple rear camber locations. Using a longer camber link will improve stability and traction (grip). Using a shorter camber link will increase steering while decreasing rear grip. Running the camber link in the inside position on the camber block will give your 1/10 Strike SCT more steering entering the turn as it will let the 1/10 Strike SCT set over the rear tire and give you more forward traction exiting the turn. As you move the camber link towards the outside of the 1/10 Strike SCT, you will gain less initial steering, however, you will gain more steering as the 1/10 Strike SCT exits the turn. The 1/10 Strike SCT has the capabilities of a lower row of holes on the camber block for the inner camber link location. The lower hole gives the 1/10 Strike SCT more camber gain (more angle relative to arm = more camber gain). This can be helpful when the surface gets bumpy and rutted to help the rear end of the 1/10 Strike SCT go through the bumps easier due to the increased camber gain of the tires.

Outboard Camber Location:

Running the camber link in the inside position on the hub will generate more rotation entering a turn, but decrease steering on exit. Running the camber link in the furthest outer position on the hub will generate more stability entering a turn and increase steering on exit.

Toe-In:

The stock toe-in is 3 degrees of inboard per side and 0 degrees in the hub.

Anti/Pro-Squat:

Increasing anti-squat is generated by raising the front of the pivot block, relative to the rear of the pivot. This will increase initial steering and forward traction. You can increase anti-squat in 1 degree increments by using two .030 washers between the front of the pivot plate and pivot block.

Tuning the Rear End of the 1/10 Strike SCT (CONT'D)

Pro-squat is generated by raising the rear of the pivot relative to the front. This will decrease forward traction and initial steering, but provide more on-power steering on high-traction surfaces. Pro-squat will also help the 1/10 Strike SCT from pulling wheelies on high-bite surfaces.

Tuning the Chassis of the 1/10 Strike SCT

Slipper Adjustment:

After fully tightening the adjustment nut (so the coils of the spring just touch) loosen the slipper adjustment nut 2 1/2 turns. This will be a good starting point for your slipper settings.



Ride Height:

This is the height of the chassis in relation to the surface. It is an adjustment that affects the way your 1/10 Strike SCT turns and goes through bumps. To check the ride height, drop one end (front or rear) of the 1/10 Strike SCT from about a 5-6 inch height onto a flat surface. Once the 1/10 Strike SCT settles into a position, check the height of that end of the 1/10 Strike SCT in relationship to the surface. To raise the ride height, lower the shock collar on the shock evenly on the end (front or rear) of the 1/10 Strike SCT that you are working on. To lower the ride height, raise the shock collar. Both left and right nuts should be adjusted evenly.

Every driver likes a little different feel so you should try small ride height adjustments to obtain the feel you like. This should be one of the last adjustments after everything else has been dialed in (tuned). Do not use ride height adjustment as a substitute for a change in spring rate.

Tuning the Chassis of the 1/10 Strike SCT (CONT'D)

Battery Position:

This is a critical adjustment that is often overlooked but can be very useful. Start by running the battery spaced in the back (standard setup with 6-cell battery pack). Having the battery in the back can improve rear traction on slippery surfaces and steering response. Having the battery back too far can cause the rear end to swing through turns on some tracks and “dump” the rear end causing instability issues. This is a result of having the weight too far back. The 1/10 Strike SCT comes equipped with foam battery spacers to accommodate different size battery packs.

Wheels and Tires:

The tires come pre-mounted with the vehicle and should be checked to make certain they stay glued to the wheels. The wheel spinning speeds can pull the rubber tire away from the rim. When a tire or tires come loose from the rim, you will notice the vehicle is hard to control.

Tip the vehicle on its side and using both hands to hold one wheel at a time, use your thumb to press the tire away from the rim. If you see a tire pull away from the rim, use Losi Tire Glue (LOSA7880 thick or LOSA7881 thin) to re-glue. It only takes a small drop of glue generally. Be careful; this is CA-type glue and you do not want to glue your fingers to the wheel and tire.

Use safety goggles when gluing tires.

Check the mounting of the tire periodically to ensure proper performance and handling.

Steering Assembly:

Occasionally, check the steering assembly and you may notice increased looseness. There are several components which will wear out from use: tie rod ends (part LOSB2015), the servo saver (part LOSB2356). You can easily replace these components to restore factory specifications.



Adjusting Gear Mesh:

Incorrect gear mesh is the most common cause of stripped spur gears. To set the gear mesh, one method is to cut a narrow strip of notebook paper and thread it in between the gears. Loosen the motor screws and slide the motor and pinion gear into the spur gear. Retighten the motor screws and then remove the strip of paper. Or you can loosen the motor and carefully slide the motor leaving a small amount of backlash (play) between the spur and pinion gears. It should not be tight and if you look up-close there should be slight movement of the spur before contacting the teeth on the pinion gear.

Gear Ratio:

Changing the gearing provides you a quick and easy way to tune the 1/10 Strike SCT. Use the temperatures of both the motor and your battery pack as a guide to gearing to your environment. When the Motor is above 160-170 degrees Fahrenheit or the batteries are above 125-135 degrees Fahrenheit, these are both strong indications that you should drop the pinion size smaller. This would be a lower gear ratio or larger number, for example from 11.25 to 12.40. Going up a pinion size is called gearing higher or a small number, for example 11.25 to 10.6, and will increase power consumption and allow more speed.

Use the following formula to calculate the overall ratio for combinations not listed on the gear chart:

$$\left(\frac{\text{Spur Gear Size}}{\text{Pinion Gear Size}} \right) \times 2.55 = \text{Final Drive Ratio}$$

		PINION													
		17	18	19	20	21	22	23	24	25	26	27	28	29	30
SPUR	86	12.90	12.18	11.54	10.97	10.44	9.97	9.53	9.14	8.77	8.43	8.12	7.83	7.56	7.31
	88	13.20	12.47	11.81	11.22	10.69	10.20	9.76	9.35	8.98	8.63	8.31	8.01	7.74	7.48
	90	13.50	12.75	12.08	11.48	10.93	10.43	9.98	9.56	9.18	8.83	8.50	8.20	7.91	7.65

When using higher gear ratios, it is extremely important to monitor the temperatures of the battery and motor. If the battery is extremely hot, and/or the motor is so hot that you cannot touch it, most likely you are over geared and drawing a lot of current. The gear combination that comes on the 1/10 Strike SCT (20-tooth pinion / 90-tooth Spur) provides the power for running through mowed grass and off-road dirt surfaces.

Storage:

When you are through running the model for the day,

- Blow it off with compressed air or use a soft bristled paint brush to dust off the vehicle.
- Always disconnect and remove the battery from the model whenever the model is stored. If the model will be stored for a long time, then also remove the batteries from the transmitter.

Troubleshooting Your 1/10 Strike SCT

Many questions are the result of simple user errors or minor adjustments which are easily addressed. If after reading below you cannot resolve your problem, then please call the Horizon Support Team at 1-877-504-0233.

Radio system does not work properly:

If the power light on the transmitter is not turning on, first ensure the batteries are installed correctly. You should also check that the batteries are good and/or if rechargeable are fully charged. Replace them if needed. If the power light is blinking, then the transmitter batteries are weak and should be replaced.

Short radio range:

If the radio range appears short, make sure the batteries are all fully charged and/or are in good condition. Another tip is to make sure that your receiver's antenna is free from cuts, abrasions or kinks.

Steering assembly:

Occasionally, check the steering assembly and you may notice increased looseness. There are a couple components which will wear out from use: tie rod ends (LOSB2015); the servo saver (LOSB2356). You can easily replace these components to restore factory specifications.

Steering works but the motor will not run:

The speed control may have gotten too hot and thermally shut down. Allow time for the speed control to cool. If this is the problem and has happened a few times, consider using a smaller pinion or a larger spur gear.

Check the transmission; do the rear wheels spin easily?

Check that a motor wire has not come loose.

Verify that the electronic speed control is plugged into the throttle channel of the receiver.

Check using another battery. Contact the Horizon Support Team at 1-877-504-0233 for service instructions.

Steering servo does not work:

Check all wires, radio system, battery connectors and the battery pack. Contact Horizon Support Team at 1-877-504-0233 for service instructions.

Motor runs backwards:

The black wire lead from the motor should be connected to the black wire lead from the ESC and the same for the red wires. If not, please correct by swapping the wires. If you are still experiencing problems please contact the Horizon Support Team at 1-877-504-0233.

Motor starts running immediately after the battery has been connected:

There may be internal ESC damage. Contact the Horizon Support Team at 1-877-504-0233.

Vehicle runs slowly/slow acceleration:

Check the battery connectors.

Confirm that the battery is charged.

Vehicle will not reverse:

Make sure the throttle trim is at neutral.

Recalibrate/Set up the ESC (see page 8).

Check to see if the ESC is in forward only mode that does not have reverse active.

Keep stripping spur gears:

Improper gear mesh, refer to page 18.

Improperly adjusted slipper, refer to page 17.



Warranty Information

Age Recommendation

14 years or over. This is not a toy. This product is not intended for use by children without direct adult supervision.

Warranty Period

Exclusive Warranty- Horizon Hobby, Inc., (Horizon) warranties that the Products purchased (the "Product") will be free from defects in materials and workmanship at the date of purchase by the Purchaser.

Limited Warranty

(a) This warranty is limited to the original Purchaser ("Purchaser") and is not transferable. REPAIR OR REPLACEMENT AS PROVIDED UNDER THIS WARRANTY IS THE EXCLUSIVE REMEDY OF THE PURCHASER. This warranty covers only those Products purchased from an authorized Horizon dealer. Third party transactions are not covered by this warranty. Proof of purchase is required for warranty claims. Further, Horizon reserves the right to change or modify this warranty without notice and disclaims all other warranties, express or implied.

(b) Limitations- HORIZON MAKES NO WARRANTY OR REPRESENTATION, EXPRESS OR IMPLIED, ABOUT NON-INFRINGEMENT, MERCHANTABILITY OR FITNESS FOR A PARTICULAR PURPOSE OF THE PRODUCT. THE PURCHASER ACKNOWLEDGES THAT THEY ALONE HAVE DETERMINED THAT THE PRODUCT WILL SUITABLY MEET THE REQUIREMENTS OF THE PURCHASER'S INTENDED USE.

(c) Purchaser Remedy- Horizon's sole obligation hereunder shall be that Horizon will, at its option, (i) repair or (ii) replace, any Product determined by Horizon to be defective. In the event of a defect, these are the Purchaser's exclusive remedies. Horizon reserves the right to inspect any and all equipment involved in a warranty claim. Repair or replacement decisions are at the sole discretion of Horizon. This warranty does not cover cosmetic damage or damage due to acts of God, accident, misuse, abuse, negligence, commercial use, or modification of or to any part of the Product. This warranty does not cover damage due to improper installation, operation, maintenance, or attempted repair by anyone other than Horizon. Return of any goods by Purchaser must be approved in writing by Horizon before shipment.

Damage Limits

HORIZON SHALL NOT BE LIABLE FOR SPECIAL, INDIRECT OR CONSEQUENTIAL DAMAGES, LOSS OF PROFITS OR PRODUCTION OR COMMERCIAL LOSS IN ANY WAY CONNECTED WITH THE PRODUCT, WHETHER SUCH CLAIM IS BASED IN CONTRACT, WARRANTY, NEGLIGENCE, OR STRICT LIABILITY. Further, in no event shall the liability of Horizon exceed the individual price of the Product on which liability is asserted. As Horizon has no control over use, setup, final assembly, modification or misuse, no liability shall be assumed nor accepted for any resulting damage or injury. By the act of use, setup or assembly, the user accepts all resulting liability.

Damage Limits (CONT'D)

If you as the Purchaser or user are not prepared to accept the liability associated with the use of this Product, you are advised to return this Product immediately in new and unused condition to the place of purchase.

Law: These Terms are governed by Illinois law (without regard to conflict of law principals).

Safety Precautions

This is a sophisticated hobby Product and not a toy. It must be operated with caution and common sense and requires some basic mechanical ability. Failure to operate this Product in a safe and responsible manner could result in injury or damage to the Product or other property. This Product is not intended for use by children without direct adult supervision. The Product manual contains instructions for safety, operation and maintenance. It is essential to read and follow all the instructions and warnings in the manual, prior to assembly, setup or use, in order to operate correctly and avoid damage or injury.

Questions, Assistance, and Repairs

Your local hobby store and/or place of purchase cannot provide warranty support or repair. Once assembly, setup or use of the Product has been started, you must contact Horizon directly. This will enable Horizon to better answer your questions and service you in the event that you may need any assistance. For questions or assistance, please direct your email to productsupport@horizonhobby.com, or call 877.504.0233 toll free to speak to a service technician.

Inspection or Repairs

If this Product needs to be inspected or repaired, please call for a Return Merchandise Authorization (RMA). Pack the Product securely using a shipping carton. Please note that original boxes may be included, but are not designed to withstand the rigors of shipping without additional protection. Ship via a carrier that provides tracking and insurance for lost or damaged parcels, as Horizon is not responsible for merchandise until it arrives and is accepted at our facility. A Service Repair Request is available at www.horizonhobby.com on the "Support" tab. If you do not have internet access, please include a letter with your complete name, street address, email address and phone number where you can be reached during business days, your RMA number, a list of the included items, method of payment for any non-warranty expenses and a brief summary of the problem. Your original sales receipt must also be included for warranty consideration. Be sure your name, address, and RMA number are clearly written on the outside of the shipping carton.

Warranty Inspection and Repairs

To receive warranty service, you must include your original sales receipt verifying the proof-of-purchase date. Provided warranty conditions have been met, your Product will be repaired or replaced free of charge. Repair or replacement decisions are at the sole discretion of Horizon Hobby.

Warranty Information (CONT'D)

Non-Warranty Repairs

Should your repair not be covered by warranty the repair will be completed and payment will be required without notification or estimate of the expense unless the expense exceeds 50% of the retail purchase cost. By submitting the item for repair you are agreeing to payment of the repair without notification. Repair estimates are available upon request. You must include this request with your repair. Non-warranty repair estimates will be billed a minimum of 1/2 hour of labor. In addition you will be billed for return freight. Please advise us of your preferred method of payment. Horizon accepts money orders and cashiers checks, as well as Visa, MasterCard, American Express, and Discover cards. If you choose to pay by credit card, please include your credit card number and expiration date. Any repair left unpaid or unclaimed after 90 days will be considered abandoned and will be disposed of accordingly. Please note: non-warranty repair is only available on electronics and model engines.

Electronics requiring inspection or repair should be shipped to the following address:

Horizon Service Center
4105 Fieldstone Road
Champaign, Illinois 61822
USA

All other Products requiring warranty inspection or repair should be shipped to the following address:

Horizon Product Support
4105 Fieldstone Road
Champaign, Illinois 61822
USA

Please call 877-504-0233 or e-mail us at productsupport@horizonhobby.com with any questions or concerns regarding this product or warranty.

United Kingdom

Electronics and engines requiring inspection or repair should be shipped to the following address:

Horizon Hobby UK
Units 1-4 Ployters Rd
Staple Tye, Harlow
Essex
CM18 7NS
United Kingdom

Please call +44 (0) 1279 641 097 or email us at sales@horizonhobby.co.uk with any questions or concerns regarding this product or warranty.

CE Compliance Information for the European Union

Instructions for Disposal of WEEE by Users in the European Union

This product must not be disposed of with other waste. Instead, it is the user's responsibility to dispose of their waste equipment by handing it over to a designated collection point for the recycling of waste electrical and electronic equipment. The separate collection and recycling of your waste equipment at the time of disposal will help to conserve natural resources and ensure that it is recycled in a manner that protects human health and the environment. For more information about where you can drop off your waste equipment for recycling, please contact your local city office, your household waste disposal service or where you purchased the product.



UK	DE	DK	BG	SE
FI	EE	LV	LT	PL
CZ	SK	HU	RO	SI
AT	IT	ES	PT	IE
NL	LU	MT	CY	GR



Declaration of Conformity

(in accordance with ISO/IEC 17050-1)

No. HH2009080901

Product(s): Strike RTR
Item Number(s): LOSB0105

Equipment class: 2

The object of declaration described above is in conformity with the requirements of the specifications listed below, following the provisions of the European R&TTE directive 1999/5/EC:

EN 300-328 Technical requirements for
Radio equipment.
EN 301 489-1, 301 489-17 General EMC requirements

Signed for and on behalf of:
Horizon Hobby, Inc.
Champaign, IL USA
Aug 09, 2009

Steven A. Hall

Vice President
International Operations and Risk Management
Horizon Hobby, Inc.

Declaration of Conformity

(in accordance with ISO/IEC 17050-1)

No. HH2009080902

Product(s): Strike BND
Item Number(s): LOSB0105BD

Equipment class: 1

The object of declaration described above is in conformity with the requirements of the specifications listed below, following the provisions of the European R&TTE directive 1999/5/EC:

EN 301 489-1, 301 489-17 General EMC requirements

Signed for and on behalf of:
Horizon Hobby, Inc.
Champaign, IL USA
Aug 09, 2009

Steven A. Hall

Vice President
International Operations and Risk Management
Horizon Hobby, Inc.

RC Terminology

BEC (Battery Elimination Circuit) – The BEC is used to eliminate the need for a receiver pack to power the radio system. On most electric vehicles this is located in the electronic speed control (ESC), but can also be a stand-alone device.

BIND Process – Programming a receiver to recognize the GUID code of only one specific transmitter or transmitter module.

Calibration – Also called ESC setup. It is the process used to match the transmitter throttle, brake and neutral to the ESC.

Current – Refers to the power flow from the battery to the ESC and motor when used in the RC vehicle environment. Typically this is measured in ampere or amp.

Deadband – This refers to the amount of travel (movement) on the transmitter trigger before the vehicle is requesting the ESC to move the vehicle forward or backwards. It is an advanced adjustment used by experienced drivers.

DSM – (Digital Spectrum Modulation) – The 2.4GHz technology of Spektrum radios.

ESC (Electronic Speed Control) – The ESC is what translates the signals passed from the transmitter trigger through the receiver into commands that reach the motor to signal forward or reverse, acceleration or braking. The Xcelorin system is an advanced electronic speed controller that is very efficient in passing precise requests to the brushless motor. The BEC is also controlled by the ESC along with the Low Voltage Protection circuit.

GUID – Globally Unique Identification Code. Each individual module or radio is factory programmed with its own unique serial code. In the binding process, the receiver is programmed to only recognize the GUID code of one specific radio or module.

LiPo – A lithium polymer battery's abbreviation indicating the chemistry used in these rechargeable batteries. These batteries require special attention by the user and are only recommended for the most experienced of users.

mAh – The milliampere hour abbreviation, which represents the capacity of a battery pack. The higher this rating the longer the run time of each charge.

Neutral Position – Referring to the transmitter when at rest, meaning the throttle trigger and steering have no input. When you turn the transmitter on, set it to the side while turning the car on, the transmitter will be in a neutral state.

NiMH – The abbreviation for nickel-metal hydride rechargeable batteries. These have replaced the use of NiCd batteries as the battery of choice in RC vehicles.

Profiles – The MSC-12L has four (4) preset profiles. Forward/Reverse, Forward Only, Forward/Reverse Learning profile with slower acceleration and Crawler (to be used for Crawling vehicles only). The Forward only profile can be selected for racing purposes. The Forward/Reverse profile and Learning profile are great for running in your neighborhood.

Receiver – A device mounted into the vehicle that receives and decodes a signal sent by a transmitter. Servos, ESC and other devices are plugged into the receiver.

Resistance – As used here refers to the power loss from the battery to the ESC and motor. Typically this is measured in Ohms. Too much resistance between the battery, ESC and motor can result in low performance and run time.

Servo – An electronic device connected to the receiver used to actuate steering control of the vehicle.

Spektrum – The technology brand of 2.4GHz radio system supplied with the 1/10 Strike SCT. The use of this technology eliminates the concern of conflicting frequencies found with older legacy radio systems. It further reduces to a minimum potential radio interference common with the legacy radio systems of the past.

Transmitter – Is the device held in your hand that relays steering and throttle/brake requests made to the receiver.

Trim – This is a setting used on the transmitter to make fine adjustments to the steering or throttle/brake trigger. For steering you would use the trim to make the adjustment for the vehicle to drive straight without adding steering input to the transmitter.

Thermal Shutdown – Refers to the ESC operating temperature. The MSC-12SL ESC monitors its internal temperature and will automatically prevent the ESC from delivering power to the motor, preventing damage due to overheating the ESC's electronics.



Replacement Parts List

Part Number	Description	Price
LOSA6215	#4 Narrow Washers (10).....	\$1.99
LOSA6300	4-40 Hex nuts	\$1.49
LOSA6903	Sealed Ball Bearing 3/16 x 3/8.....	\$6.99
LOSA8200	Body Clips.....	\$1.49
LOSB0805	LSR-3000 DSM Transmitter	\$62.99
LOSB0806	MRX-3000 DSM Receiver	\$74.99
LOSB0818	MSX Digital Servo	\$16.99
LOSB2005	Steering Blocks.....	\$4.99
LOSB2006	Front Caster Blocks	\$4.99
LOSB2007	Front Suspension Arm.....	\$6.99
LOSB2008	Upper Shock Mount Bushings.....	\$3.99
LOSB2011	3mm E-clips	\$1.99
LOSB2015	Ball Cup Set.....	\$17.99
LOSB2025	Front Nose Plate and Spacer.....	\$7.99
LOSB2038	Rear Suspension Arm: STRIKE	\$10.99
LOSB2039	Rear Toe Block: STRIKE	\$6.99
LOSB2041	Camber and Brace Set: STRIKE	\$14.99
LOSB2043	Front Axle: STRIKE.....	\$8.99
LOSB2044	Front Pivot Block: STRIKE	\$6.99
LOSB2107	Rear Hub Carrier.....	\$5.99
LOSB2108	Rear Dogbones	\$9.99
LOSB2164	Shock Tower Set: STRIKE	\$8.49
LOSB2215	Front Tie Brace: STRIKE.....	\$4.99
LOSB2216	Rear Tie Brace: STRIKE	\$4.99
LOSB2218	Transmission Brace Set: STRIKE	\$6.99
LOSB2219	Ladder Brace Set: STRIKE	\$9.99
LOSB2238	Battery Strap	\$4.99
LOSB2241	Steering Brace.....	\$5.99
LOSB2283	Chassis, STRIKE	\$29.99
LOSB2284	Speed Control Mount.....	\$11.99
LOSB2356	Servo Saver Plastic Parts	\$4.99
LOSB2357	Servo Saver Metal Parts	\$11.99
LOSB2404	Front Bumper Set: STRIKE	\$12.99
LOSB2405	Rear Bumper Set: STRIKE	\$12.99
LOSB2420	Side Bumpers: STRIKE	\$7.99
LOSB2453	Body Mount Set: STRIKE	\$7.99
LOSB2735	Locknut Set	\$3.99
LOSB2829	Shock Body Set, Medium (PR): STRIKE	\$16.49
LOSB2847	Shock Shaft, Medium: STRIKE	\$4.99
LOSB2902	Shock Rod Ends.....	\$4.99
LOSB2903	Shock Rebuild Kit.....	\$6.99
LOSB2958	Spring Set, White: STRIKE	\$3.99
LOSB3001	Transmission Case	\$4.99
LOSB3002	Bearing Holder.....	\$4.99
LOSB3003	Gear Cover and Cap.....	\$4.99
LOSB3004	Tranny Gear Bag	\$8.99



Replacement Parts List (CONT'D)

Part Number	Description	Price
LOSB3005	Slipper Plates	\$11.99
LOSB3006	Transmission Main Shaft	\$7.99
LOSB3007	Ball Bearing 8 x12 x 3.5mm	\$4.99
LOSB3010	Slipper Rebuild Kit	\$5.99
LOSB3016	Motor Plate: STRIKE	\$7.99
LOSB3437	Spur Gear 86T	\$3.99
LOSB3438	Spur Gear 88T	\$3.99
LOSB3439	Spur Gear 90T	\$3.99
LOSB3526	Hex Set: STRIKE	\$8.99
LOSB3548	Idler Gear, Aluminum	\$9.99
LOSB3550	Rear Axles	\$9.99
LOSB3551	Differential Outdrive Set	\$9.99
LOSB3552	Differential Pin/Idler Shaft	\$4.99
LOSB3593	Metal Diff Gear: STRIKE	\$5.99
LOSB4005	Turnbuckle Set: STRIKE	\$12.99
LOSB4050	Screw Kit: STRIKE	\$16.99
LOSB4107	Hinge Pin Set (10)	\$7.99
LOSB7044	Wheels, Chrome (PR): STRIKE	\$10.99
LOSB7214	Strike Tires w/ insert (PR): STRIKE	\$20.99
LOSB8080	Strike Painted Body w/ Stickers, Blue: STRIKE	\$59.99
LOSB8082	Strike Painted Body w/ Stickers, Red: STRIKE	\$59.99
LOSB9498	Motor, 550 12T STRIKE	\$25.99
LOSB9522	MSC-12L Electronic Speed Control	\$59.99

Optional Parts for the 1/10 Strike SCT

Part Number	Description	Price
LOS4117	48 Pitch Pinion Gear, 17T.....	\$4.99
LOS4118	48 Pitch Pinion Gear, 18T.....	\$4.99
LOS4119	48 Pitch Pinion Gear, 19T.....	\$4.99
LOS4120	48 Pitch Pinion Gear, 20T.....	\$4.99
LOS4121	48 Pitch Pinion Gear, 21T.....	\$4.99
LOS4122	48 Pitch Pinion Gear, 22T.....	\$4.99
LOS4123	48 Pitch Pinion Gear, 23T.....	\$4.99
LOS4124	48 Pitch Pinion Gear, 24T.....	\$4.99
LOS4125	48 Pitch Pinion Gear, 25T.....	\$4.99
LOS4126	48 Pitch Pinion Gear, 26T.....	\$4.99
LOS4127	48 Pitch Pinion Gear, 27T.....	\$4.99
LOS4128	48 Pitch Pinion Gear, 28T.....	\$4.99
LOS4129	48 Pitch Pinion Gear, 29T.....	\$4.99
LOS4130	48 Pitch Pinion Gear, 30T.....	\$4.99
LOSA5128	2" Spring 2.5 Rate, Red	\$2.50
LOSA5129	2" Spring 2.9 Rate, Orange	\$2.50
LOSA5130	2" Spring 3.2 Rate, Silver	\$2.50
LOSA5132	2" Spring 3.5 Rate, Green	\$2.50
LOSA5134	2" Spring 3.8 Rate, Blue	\$2.50
LOSA5135	2" Spring 4.1 Rate, Black	\$2.50



Optional Parts for the 1/10 Strike SCT (CONT'D)

Part Number	Description	Price
LOSA5221	Silicone Shock Oil, 15Wt, 2 oz	\$3.99
LOSA5222	Silicone Shock Oil, 20Wt, 2 oz	\$3.99
LOSA5223	Silicone Shock Oil, 25Wt, 2 oz	\$3.99
LOSA5224	Silicone Shock Oil, 30Wt, 2 oz	\$3.99
LOSA5225	Silicone Shock Oil, 35Wt, 2 oz	\$3.99
LOSA5226	Silicone Shock Oil, 40Wt, 2 oz	\$3.99
LOSA5227	Silicone Shock Oil, 50Wt, 2 oz	\$3.99
LOSA5228	Silicone Shock Oil, 60Wt, 2 oz	\$3.99
LOSA5229	Silicone Shock Oil, 70Wt, 2 oz	\$3.99
LOSA5230	Silicone Shock Oil, 80Wt, 2 oz	\$3.99
LOSA5231	Silicone Shock Oil, 90Wt, 2 oz	\$3.99
LOSA5232	Silicone Shock Oil, 100Wt, 2 oz	\$3.99
LOSA5240	Shock Oil 6pk, 20, 25, 30, 35, 40, 45Wt	\$19.99
LOSA5241	Shock Oil 6pk, 50, 60, 70, 80, 90, 100Wt	\$19.99
LOSB2017	Steering Block Set, Aluminum	\$26.59
LOSB2018	Caster Block Set, Aluminum	\$26.59
LOSB2040	Rear Toe Block, Aluminum	\$22.99
LOSB2042	Camber Block, Aluminum	\$19.99
LOSB2045	Front Pivot Block, Aluminum	\$21.99
LOSB2109	Rear Hub Set, Aluminum	\$26.59
LOSB2142	Steering Brace	\$19.99
LOSB2217	Rear Brace, Aluminum	\$27.99
LOSB2404C	Front Bumper Set, Chrome	\$11.99
LOSB2405C	Rear Bumper Set, Chrome	\$14.99
LOSB3017	Lightened Motor Plate, Aluminum	\$19.99
LOSB3527	Hex Set, Aluminum	\$21.99
LOSB7045	Wheel Set, Black Chrome (2)	\$14.99
LOSB8079	Strike Painted Body w/ Stickers, Black	\$59.99
LOSB8081	Strike Painted Body w/ Stickers, Green	\$59.99
LOSB8083	Strike Clear Body w/ Stickers	\$35.99
LOSB9901	6-cell 4600mAh 7.2V, Side-by-side w/ EC3.....	\$59.99
LOSB9902	7-cell 4600mAh 8.4V Side by-side w/ EC3.....	\$74.99
LOSB9903	6-cell 3600mAh 7.2 NiMH	\$59.99
LOSB9861	7.4V 5000mAh 2S LiPo, 20C w/ EC3	\$84.99
LOSB9862	7.4V 4400mAh 2S LiPo, 30C w/ EC3	\$99.99
LOSB9868	7.4V 3600mAh 2S LiPo, 20C w/ EC3	\$74.99
LOSB9553	1/10th Xcelorin S 17.5T Brushless Combo	\$224.99
LOSB9555	1/10th Xcelorin S 13.5T Brushless Combo	\$224.99
LOSB9554	1/10th Xcelorin S 10.5T Brushless Combo	\$224.99
LOSB9606	MultiPro Intelligent Balance Charger	\$109.99

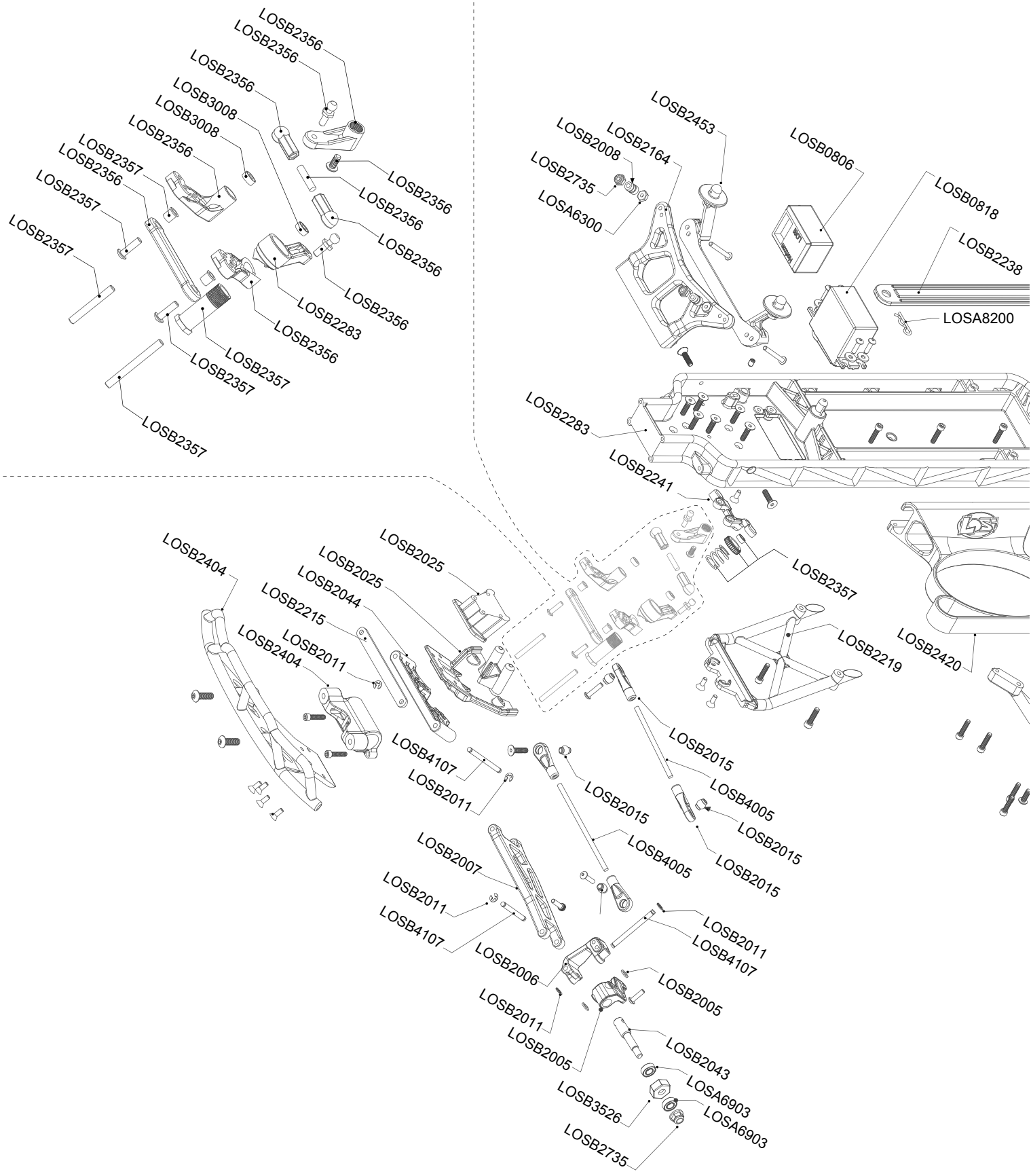

Unless otherwise noted:
 All fasteners are contained in the 1/10 Strike SCT Screw Kit - LOSB4050

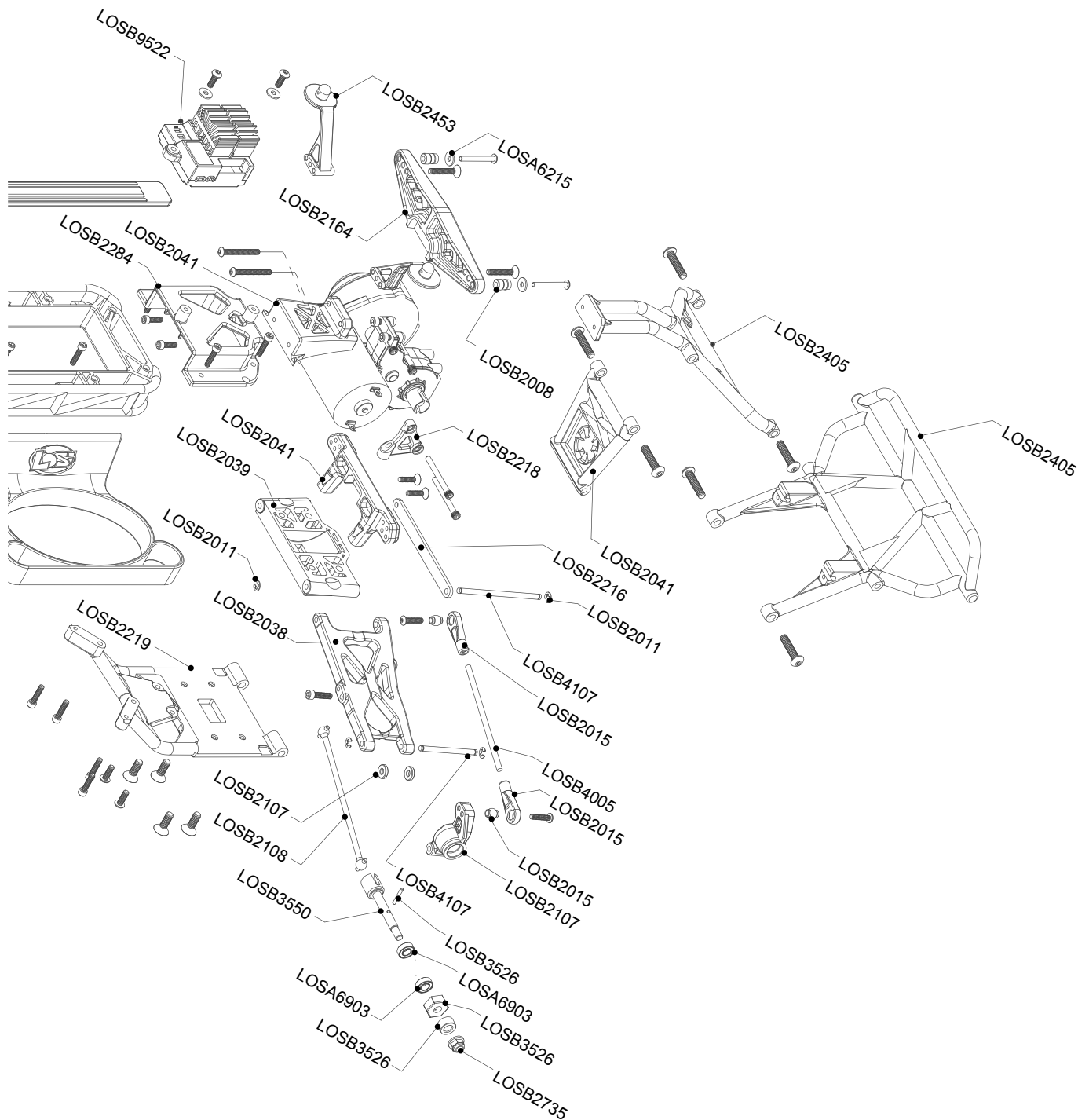

Unless otherwise noted:
 All fasteners are contained in the 1/10 Strike SCT Screw Kit - LOSB4050

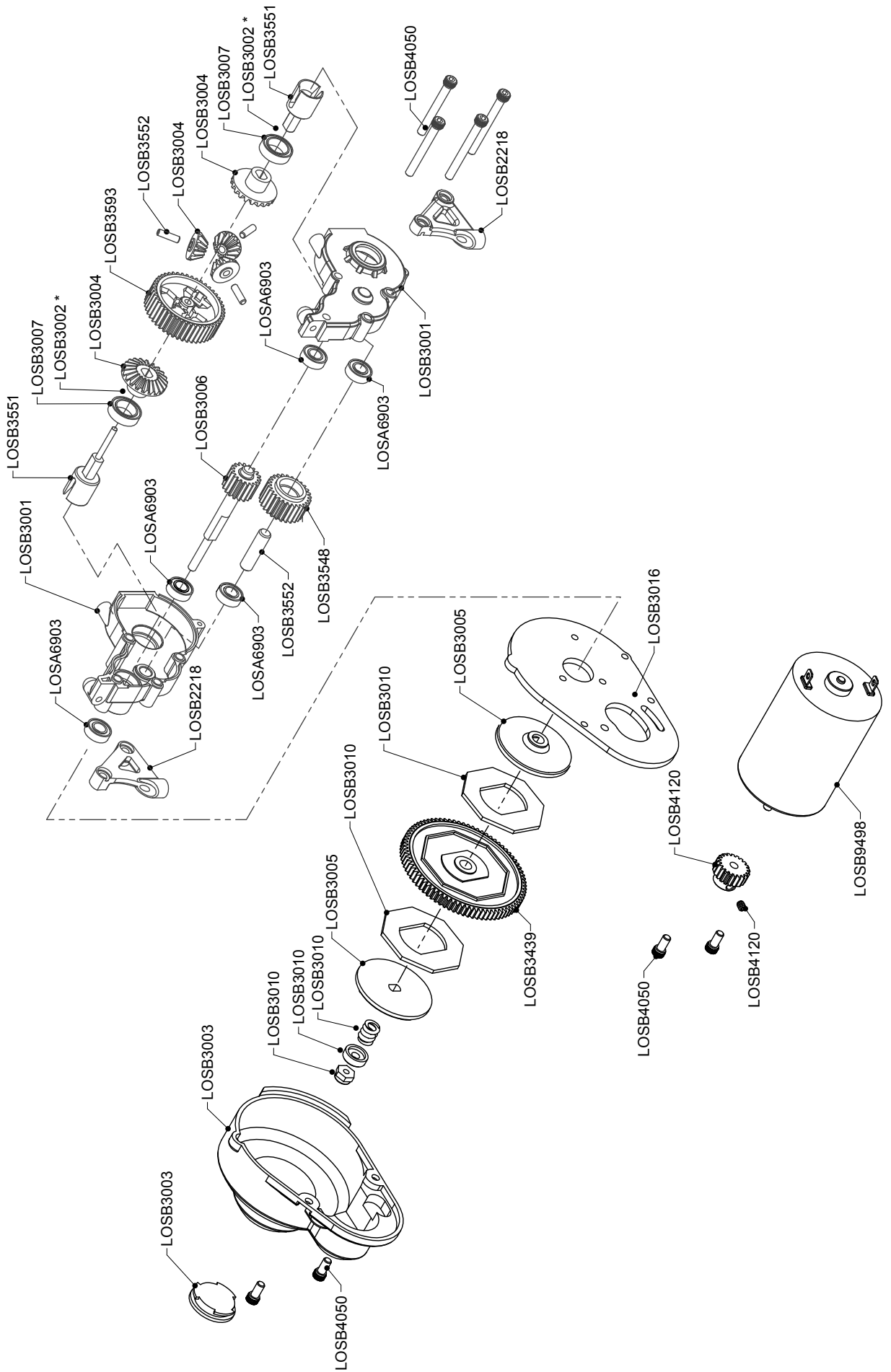

* LOSB3002 (Bearing Holder) Not shown

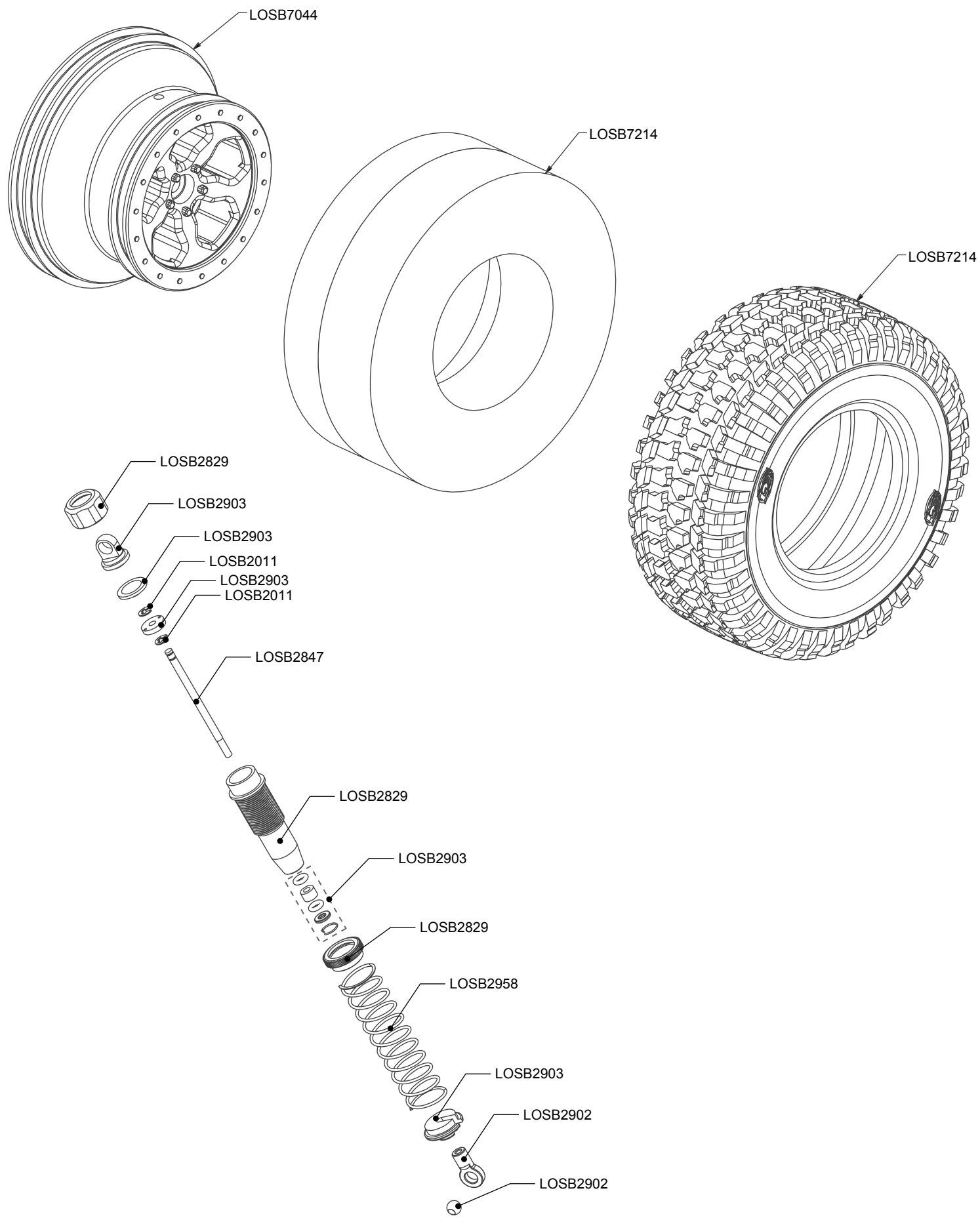

Notes:

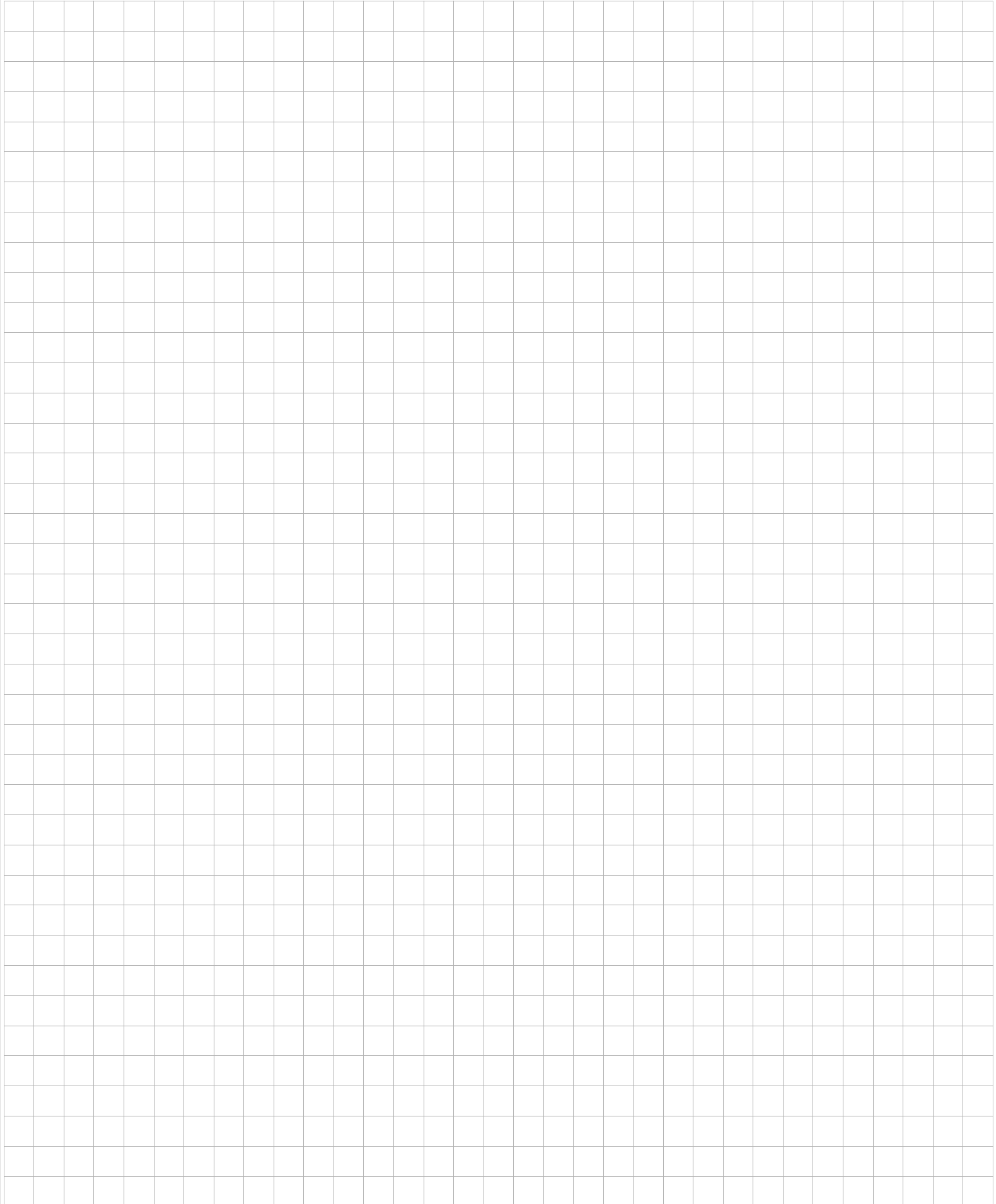
A large, empty grid area for taking notes, consisting of a uniform pattern of small squares.

STRIKE SCT GETTING AIRBORNE





STRIKE SCT GETTING AIRBORNE



SETUP SHEET



Name: _____	Date: _____ Event: _____
City: _____ State: _____	Track: _____

Track <input type="checkbox"/> Indoor <input type="checkbox"/> Tight <input type="checkbox"/> Smooth <input type="checkbox"/> Hard Packed <input type="checkbox"/> Blue Groove <input type="checkbox"/> Wet <input type="checkbox"/> Low Bite <input type="checkbox"/> High Bite
Conditions <input type="checkbox"/> Outdoor <input type="checkbox"/> Open <input type="checkbox"/> Rough <input type="checkbox"/> Loose/Loamy <input type="checkbox"/> Dry <input type="checkbox"/> Dusty <input type="checkbox"/> Med Bite <input type="checkbox"/> Other _____

Front Suspension

Toe: 0°

Ride Height: Arms Level

Camber: -2°

Caster: N/A

Oil: Losi 30 wt

Piston: Stock

Spring: Strike

Limiters: N/A

Spindle Height: N/A

Bump Steer: N/A

Camber Link: 1-A

Shock Location: 1-Middle

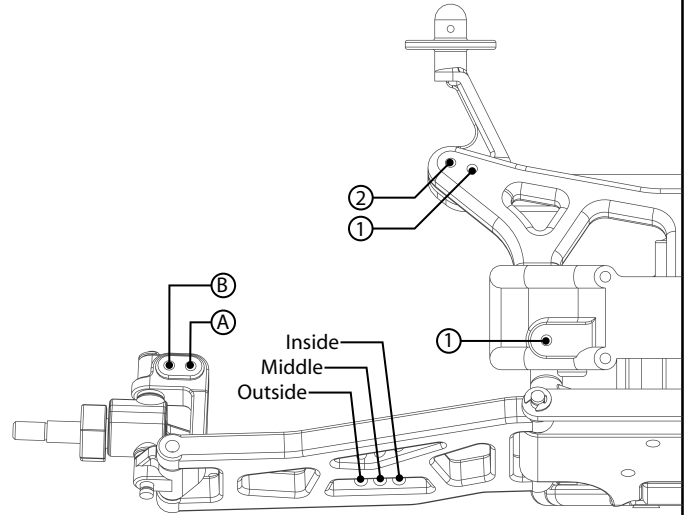

Notes: _____

Rear Suspension

Toe: 0° (Pivot Block has 2°)

Ride Height: Arms Level

Camber: -2°

Hub Spacing: Middle

Drive Shafts/Outdrives: N/A

Oil: Losi 30 wt

Piston: Stock

Spring: Strike

Limiters: N/A

Camber Link: 3-A

Shock Location: 2-Inside

Battery Position: Rear

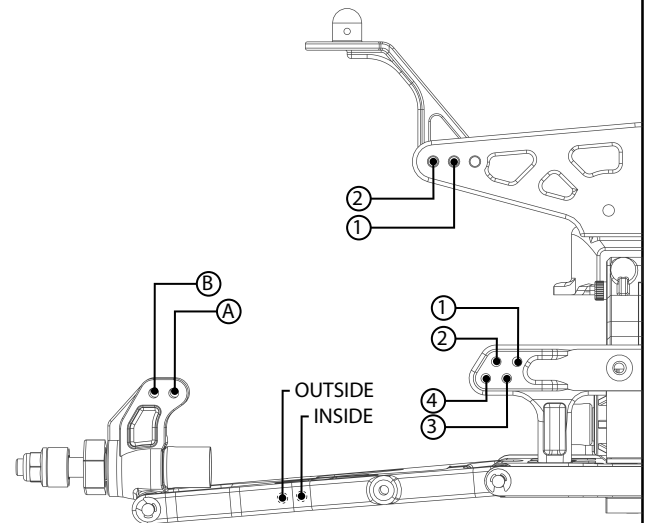

Notes: _____

Tires: Type _____ Compound _____ Insert _____ Additive _____	Motor: <u>Losi 550</u>
Front: _____	Spur: <u>90</u>
Rear: _____	Pinon: <u>20</u>

Notes: _____



SETUP SHEET



Name: _____	Date: _____ Event: _____
City: _____ State: _____	Track: _____

Track Indoor Tight Smooth Hard Packed Blue Groove Wet Low Bite High Bite
 Conditions Outdoor Open Rough Loose/Loamy Dry Dusty Med Bite Other _____

Front Suspension

Toe: _____
 Ride Height: _____
 Camber: _____
 Caster: _____
 Oil: _____
 Piston: _____
 Spring: _____
 Limiters: _____
 Spindle Height: _____
 Bump Steer: _____
 Camber Link: _____
 Shock Location: _____

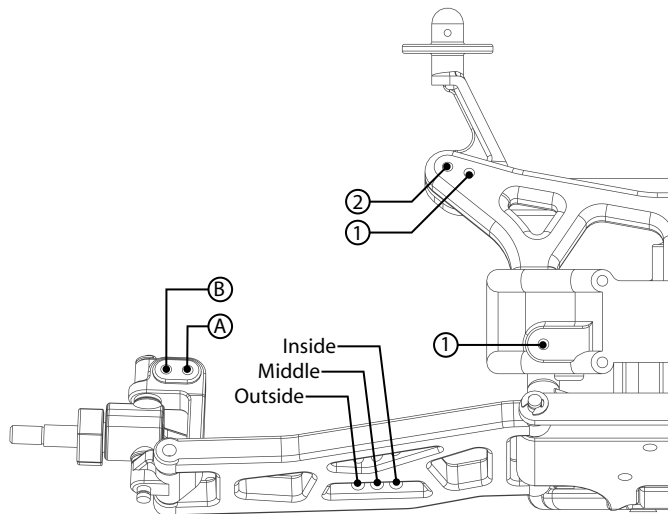

Notes: _____

Rear Suspension

Toe: _____
 Ride Height: _____
 Camber: _____
 Hub Spacing: _____
 Drive Shafts/Outdrives: _____
 Oil: _____
 Piston: _____
 Spring: _____
 Limiters: _____
 Camber Link: _____
 Shock Location: _____
 Battery Position: _____

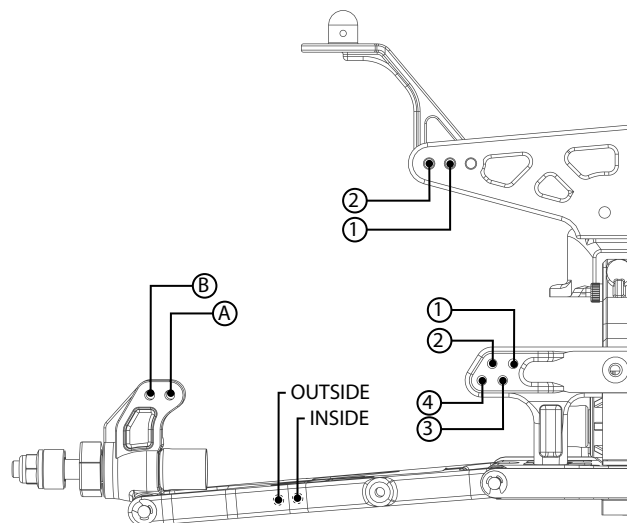

Notes: _____

Tires: _____	Type _____	Compound _____	Insert _____	Additive _____	Motor: _____
Front: _____	_____	_____	_____	_____	Spur: _____
Rear: _____	_____	_____	_____	_____	Pinon: _____

Notes: _____



STRIKE™

1/10-SCALE ELECTRIC SHORT COURSE TRUCK



©2009 Losi, A division of Horizon Hobby, Inc.
Not responsible for typographical errors.
All pricing subject to change without notice.

800-0359

The Spektrum trademark is used with permission of Bachmann Industries, Inc. Spektrum radios and accessories are exclusively available from Horizon Hobby, Inc.

Printed in China